

Optimal Corporation™ First to Offer Adjacent Structure Coupling Capability for Complex IC, Package and PCB Designs

New flow raises full-wave electromagnetic simulation capacity to over 1M edges

San Jose, California – May 19, 2005 – Optimal Corporation, a leading provider of high-performance EDA solutions serving the semiconductor industry, today announced the EDA industry's first full-wave adjacent structure coupling capability in Optimal's Full-Wave Signal Integrity/Power Integrity (SI/PI) Simulation Flow. Designers of IC packages and PCBs can use Optimal's PowerGrid™ and O-Wave™ products to completely model signal and power nets together on designs with over one million edges.

Current full-wave simulation tools can model either signal nets or power nets, but not both. To create an adjacent structure coupling model, users must break their model down into multiple sections and simulate each section separately. Even then, initially complex device geometry must be simplified from millions of edges down to 200,000-300,000 edges in order for other tools to be able to run the simulation to completion. The final step is to manually compile the results into one final model. This level of up-front data manipulation and results compilation is time-consuming, error-prone and substantially impacts the accuracy of the results.

Optimal developed its full-wave adjacent structure coupling capability by adding a Full-Wave Coupling module to its O-Wave product. Armed with this new Full-Wave SI/PI Flow, the user runs a simulation on selected signal nets and part of the Power/Ground nets in O-Wave. Simultaneously, PowerGrid runs a simulation on the complete Power/Ground structure which is then combined with the O-Wave results, resulting in one complete model.

"Adjacent structure coupling is a monumental breakthrough for high-speed designers. Without it, designers are forced to make risky assumptions in order to simplify the design geometry so it can be run in current tools, endangering the reliability and accuracy of the results," said, Dr. An-Yu Kuo, Chief Technology Officer and a co-founder of Optimal. "High-speed designers simply cannot afford to take risks with today's technology that could cost them time and a window of opportunity in the market."

What is Adjacent Structure Coupling?

Adjacent structure coupling is the electromagnetic (EM) interaction between adjacent structures on a given device. The structures may be physically located side by side on the same plane, or adjacently on a horizontal plane to a vertical connector. Resulting from the close proximity of adjacent structures, one structure may cause changes in the EM characteristics of itself, or of the adjacent structures nearby. Predicting and controlling these potential changes in EM characterization is imperative as devices continue to increase in complexity. Optimal's Full-Wave SI/PI Flow now enables designers to accurately simulate these EM effects in the design iteration process. Competitor tools cannot simulate the EM effects of adjacent structures. Rather, they can only simulate simpler coupling effects such as in planar (horizontally co-located) via-to-via coupling or trace-to-trace coupling.

How Users benefit from Adjacent Structure Coupling

Optimal's Full-Wave Coupling module allows users to combine S-parameter solutions from O-Wave and PowerGrid to provide a composite result for a design's signal integrity and power integrity nets. Users can extract full-wave models for applications such as simultaneous switching noise (SSN) and ground bounce analyses.

As a unique full-wave model-based simulator, PowerGrid simulates the entire geometry for a power/ground net which would otherwise be too large to solve with today's available computer technology. The PowerGrid model includes the entire geometry of a selected power net, and thus, retains the resonance information associated with a few selected signal nets and part of the power/ground nets. O-Wave then adds its very accurate S-parameter solution for signal nets and the coupling effects between the signal nets and power/ground nets. This complete composite SI/PI flow provides an easy way to create a full-wave S-parameter model with accurate power/ground plane resonance and accurate coupling between signal nets and the power/ground nets.

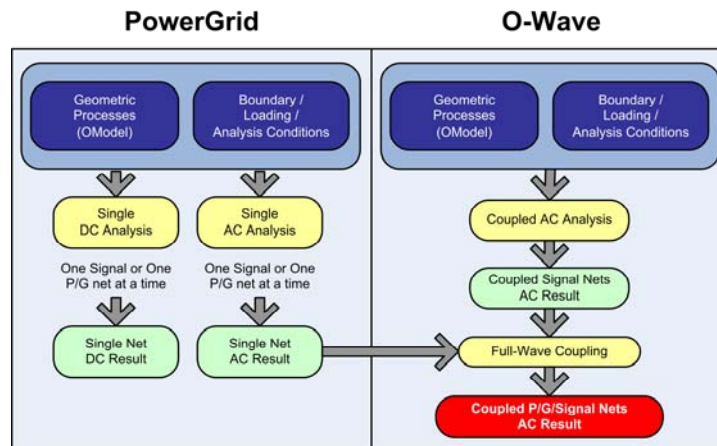

Optimal's Full-Wave SI/PI Flow can address any type of IC package design. However, users will find the greatest benefit when using it for large, complex designs containing more than one million edges. (see Figure A). Examples of device designs containing more than one million edges include: 1) differential pairs in a 15-layer flip-chip BGA package; 2) two spiral inductors on top of a 30-layer semiconductor substrate; and 3) a one foot long differential pair in a 30-layer back plane design.

Figure A: Electric field plot of one leg of a differential pair excited, that is routed between two other differential pairs above Power/Ground planes

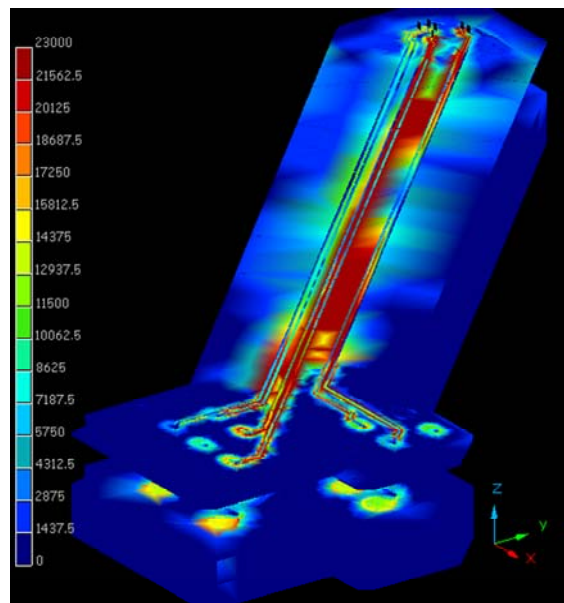

Pricing and availability

Full-Wave SI/PI Flow (which includes PowerGrid and O-Wave) is priced starting at US\$90,000 per seat for a perpetual license. For current users of only O-Wave or only PowerGrid, separate O-Wave pricing starts at US\$60,000, and separate PowerGrid pricing starts at US\$50,000. The O-Wave Full-Wave Coupling module will be released in May 2005 and will be publicly demonstrated at the 42nd Design Automation Conference in Anaheim, California at booth 367.

About Optimal Corporation

Optimal is a leading provider of high-performance EDA solutions. The company's breakthrough technology and engineering expertise have helped leading chip and system companies solve challenging high-speed design problems and bring industry-leading products to market. Additional information may be obtained online at www.optimalcorp.com or by e-mailing info@optimalcorp.com.

Optimal Corporation, the Optimal logo, O-Wave and PowerGrid are trademarks of Optimal Corporation. All other marks are the property of their respective owners. © 2005. All Rights Reserved.

-- end --

Contact Information

Kristine Perham
Optimal Corporation
+1 408-363-6300 x105
PR@optimalcorp.com

Ed Lee
Lee Public Relations
+1 650-363-0142
ed@leepr.com